

Eagle Logic Solver (ELS)

SPECIFICATION DATA

SIL-2 Rated Fire & Gas System

Table of Contents

FEATURES.....	1
OVERVIEW.....	2
ELS SAFETY CONTROLLER (ELS4851-LC-DT).....	5
Controller Specification.....	6
ELS SAFETY LOGIC WORKBENCH (ELS4841-LC-MT).....	8
ELS SAFETY I/O MODULE.....	9
ELS SAFETY ANALOG INPUT MODULE (ELS4810-HI-TX).....	10
Module Specification.....	11
ELS SAFETY DISCRETE INPUT/OUTPUT MODULE (ELS4811-I0-DC).....	12
Module Specification.....	14
OVERVIEW OF CARRIERS.....	15
CONTROLLER CARRIER.....	16
Carrier Specification.....	16
MODULE CARRIER.....	19
Carrier Specification.....	19
CARRIER EXTENDER.....	20
Carrier Specification.....	20
CARRIER EXTENDER CABLE.....	21
Specification.....	21
FIELD TERMINALS.....	22
Field Terminal Specification.....	23
POWER SUPPLIES.....	24
SYSTEM POWER.....	25
Power Supply Specification.....	25
BUSSED FIELD POWER.....	27
Power Supply Specification.....	27
NODE SERVICES POWER SUPPLY MONITOR.....	29
Module Specification.....	29
SYSTEM SPECIFICATION.....	30

Eagle Logic Solver (ELS) SIL-2 Rated Fire & Gas System

FEATURES

- SIL 2 certified 1oo1D (Single controller with diagnostics)
- Mix standard and SIL rated modules on the same node.
- On line changes supported.
- Mounts in harsh and hazardous environments.

The Det-Tronics ELS Safety System is an addition to the Det-Tronics Systems product family.

Certified according to IEC 61508 as a "Programmable Electronic Safety System", Det-Tronics ELS is suitable for use in safety-related applications up to Safety Integrity Level (SIL) 2. The system will also operate "openly" with your choice of HMI - whatever package you use.

Emergency Shutdown, Fire & Gas and Burner Management application requirements are all met, with certification to IEC 61511 for process industries and NFPA 85 for burner management systems.

Designed for SIL 2, the ELS System has been specifically developed for safety applications, with features that ensure safety designed in to the product, with a simple and straightforward Safety Manual. The net result is a product that is easy to program, configure and use.

The modular approach provides cost effective solutions to safety applications with limited I/O counts per node. And since each ELS node can accommodate up to 64 I/O modules, (each of 8 channels), the requirements of safety systems with high I/O counts are also met.

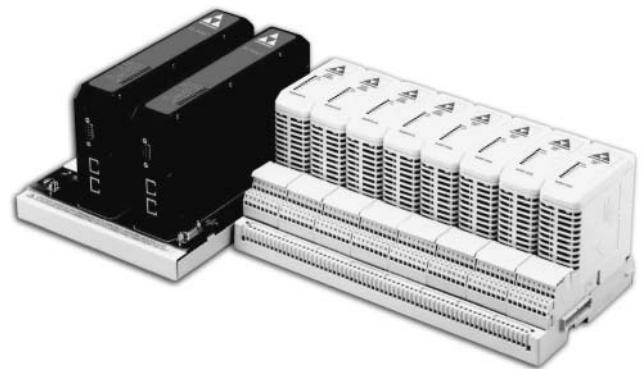

Using a 1 out of 1 with diagnostics structure (1oo1D), a single controller, input module and output module (together with the necessary field terminals, carriers and power supplies and a suitable sensor and final element) meet the basic requirements of a SIL 2 safety function.

Redundant controllers can be used to improve availability for the SIL2 safety function - with entirely bumpless transfer. Further availability enhancements can be made by the use of redundant, fault tolerant ethernet communications and power supplies.

OVERVIEW

The ELS Safety System is a "Programmable Electronic Safety System", certified according to IEC 61508 as being suitable for use in safety-related applications up to Safety Integrity Level 2.

The system is suitable for use in emergency shutdown, fire & gas and burner management applications.

On-line Changes

Where allowed by local practices - and following adequate testing and approval - new safety programs and configuration can be downloaded on-line and in real time, without interrupting the safety function.

New Additions to the Family

The Det-Tronics ELS Safety System uses the same basic structure as the Det-Tronics standard ELS System, but in addition incorporates specifically developed components. These are:

- ELS Controllers (ELS4851-LC-DT)
- Dedicated carriers for ELS Controller (ELS4751-CA-NS)
- ELS IO Modules -Analog Input with HART (ELS4810-HI-TX) and Discrete Input/Output (ELS4811-IO-DC)
- Workbench software tools for use with the ELS System (ELS4841-LC-DT)

Open Communications

ELS controller nodes communicate with one another, with historian and asset management packages and with HMI packages over a fault tolerant Ethernet LAN, running at up to 100 Mbit/s. The protocol for communication is Modbus TCP/IP - the widely supported Ethernet protocol.

Peer to Peer Communication

ELS Controllers can communicate with one another peer-to-peer via Ethernet using ELS P2P - which has been certified as suitable for use in SIL 2 applications. Robust checks and controls on access and data corruption ensure the safety of communication and allow safety functions for which the inputs and outputs are widely separated to be easily implemented - both in terms of the software programming and in the hardware design.

Mixing Safe and Standard

Standard IO Modules can be mounted on ELS Nodes - together with ELS Safety IO Modules - without affecting the node's functional safety performance. Only standard Controllers can read data from standard Modules, but both standard and ELS Safety Controllers are allowed to write to standard modules. This flexibility can simplify hardware design, where the physical constraints of the particular locality demand that such an approach be taken.

Serial Interfaces

Modbus serial interface is also available, for connection to any node (ELS or standard) by an RS485 connection. As with data from standard IO Modules, this data can be read by standard Controllers, but not by ELS Safety Controllers. Both standard and ELS Safety Controllers can write to such devices.

Comprehensive Programming Tools

The ELS System is programmed using the Workbench software package. In addition to providing the options of programming the required safety function in one of three IEC 61131-3 languages (Ladder Diagram, Function Block Diagram and Structured Text) the package also provides many useful tools to assist in testing and commissioning.

A Static Analysis tool will detect errors in an application program before it is downloaded to an ELS Safety Controller.

Restricted Access

Access to modify safety-related parameters within the configuration and application program must be restricted to authorised personnel. The ELS Safety system provides a number of layers and methods of providing this protection. Only users with "Safety Responsibility" can access the safety-related aspects of the Workbench. Only computers that the ELS Safety Controller identifies as "trusted hosts" can download new parameters. A download can only take place when an "over-ride key-switch" is set to the required position. And, if required, each ELS Safety Controller can be protected by its own password - without which access to the safety parameters is denied.

Maintaining Field Instruments

Maintenance over-rides can be implemented from operator workstations in full compliance with the guidelines from TÜV. Users define in their application the actions that must be taken to maintain a particular instrument and the ELS System then implements these pre-defined actions.

HART Capability

The ELS System allows full access to HART field devices for Emerson's AMS maintenance software, which simplifies documentation tasks and enhances safety.

Earth Leakage Detection

Earth leakage detection may be implemented using the ELS4751-CA-NS in conjunction with an input channel from an ELS4811-IO-DC Discrete Input/Output Module. Where earth leakage detection is not required, inserting a jumper in to the terminal block of the ELS4751-CA-NS disables this capability.

ELS SAFETY CONTROLLER – RUNS THE SAFETY APPLICATION PROGRAM AND CARRIES OUT DIAGNOSTIC CHECKS TO ENSURE IT IS OPERATING CORRECTLY. IF A FAULT IS DETECTED IT WILL SHUT ITSELF DOWN.

ELS SAFETY MODULE CONFIGURED FOR DIGITAL INPUTS. MONITORS THE INPUTS AND ALSO CHECKS FOR LINE FAULTS. INTERNAL DIAGNOSTICS CHECK THAT THE MODULE IS OPERATING CORRECTLY.

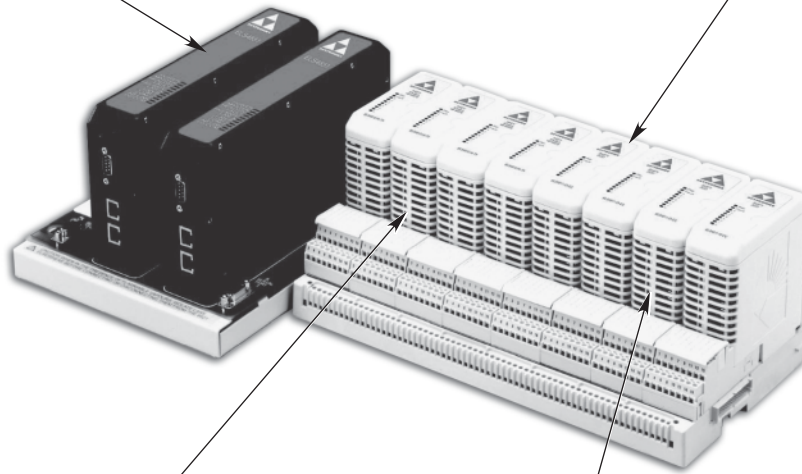

ELS SAFETY ANALOGUE INPUT MODULE MONITORS THE ANALOGUE INPUTS AND CARRIES OUT INTERNAL DIAGNOSTICS TO CHECK THAT THE MODULE IS OPERATING CORRECTLY.

ELS SAFETY MODULE CONFIGURED FOR DIGITAL OUTPUTS. OBEYS COMMANDS TO SET THE OUTPUTS SENT BY THE CONTROLLER. INTERNAL DIAGNOSTICS CHECK THAT THE MODULE IS OPERATING CORRECTLY. IF A FAULT IS DETECTED, OUTPUTS WILL BE SET TO THEIR SAFE STATE OF DE-ENERGISED.

Harsh and Hazardous Environments

The ELS Safety System is as rugged as other Det-Tronics Components: -40°C to $+70^{\circ}\text{C}$ operating ambient temperature; Zone 2 or Class 1 Division 2 hazardous area mounting; G3 corrosion resistance; and enhanced shock and vibration capability. The system will operate in the extreme environments found in process industries, allowing remote mounting and truly distributed architectures.

Event Logging

The ELS Safety System has Sequence of Events (SOE) recording capability. Data received from ELS Modules is time-stamped by the ELS Safety Controller with a resolution of better than 200ms. Data from dedicated (non-SIL) SOE modules is time-stamped with a resolution of less than 0.25ms between different channels of the same SOE module and less than 1ms between channels from different SOE modules. The ELS Controller can record up to 8000 events before its event data buffer begins to be overwritten by new data.

Reduced Cabling and Termination Costs

The ELS System offers users the opportunity to significantly reduce their spend on wiring and termination costs. Moving control and safety hardware out of the control room and on to the plant gives significant savings. The Field Terminal design allows users to avoid unnecessary spend on marshalling cabinets, cross wiring and marshalling terminals. Integral tagging and fusing further simplifies cabinet design and installation.

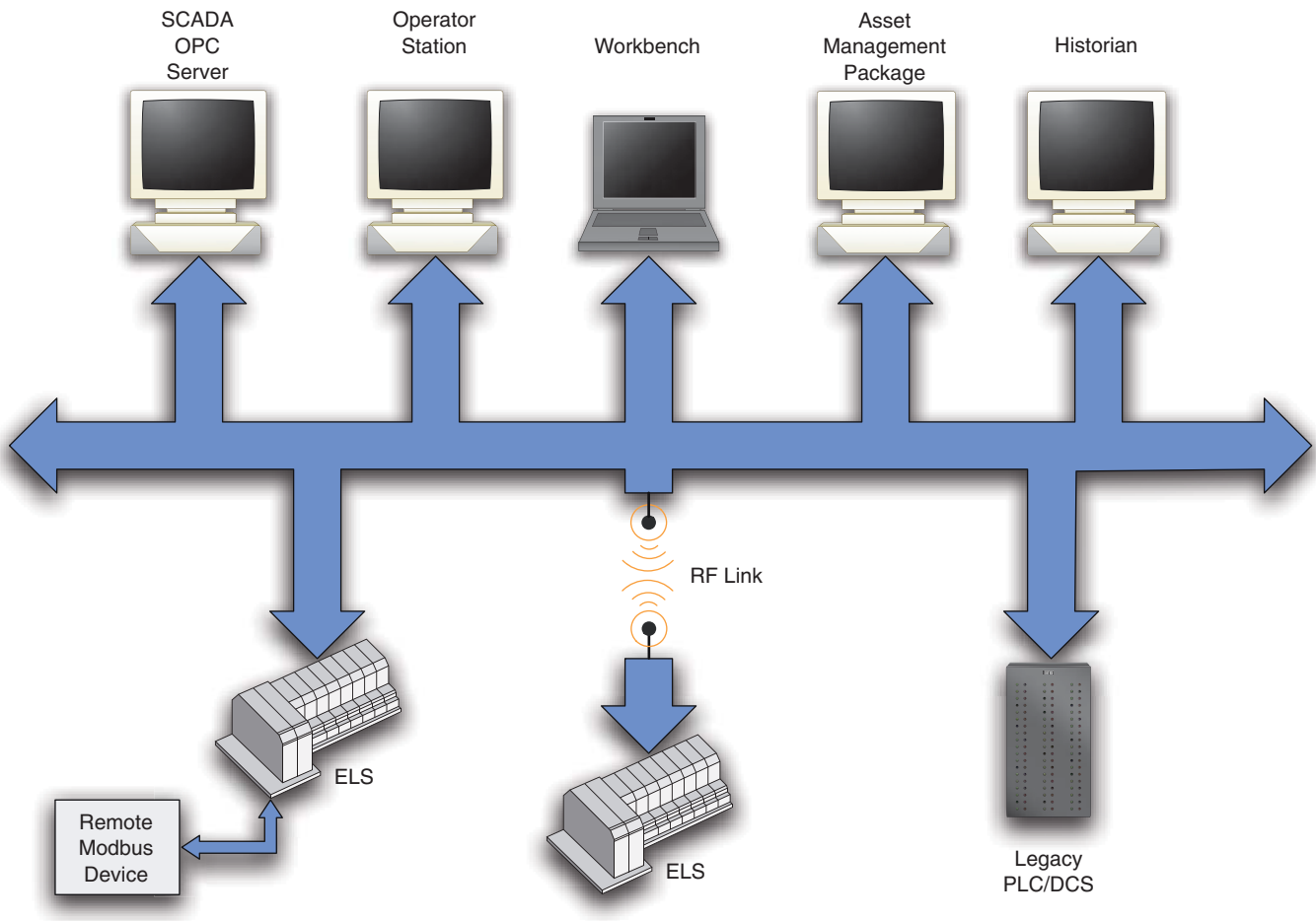

Figure 1—Typical ELS System Layout

Det-Tronics ELS on your Plant

Figure 1 shows a typical layout of a Det-Tronics ELS System, together with an OPC Server, an HMI and an asset management and historian packages all connected together via an Ethernet LAN. Also shown is the Workbench - the dedicated tool for programming and configuring ELS systems.

ELS System

ELS Node Layout and Powering Figure 2 shows a typical layout of an ELS node, with Controllers, IO Modules, Field Terminals, and Carriers. The power connections that need to be made are also shown.

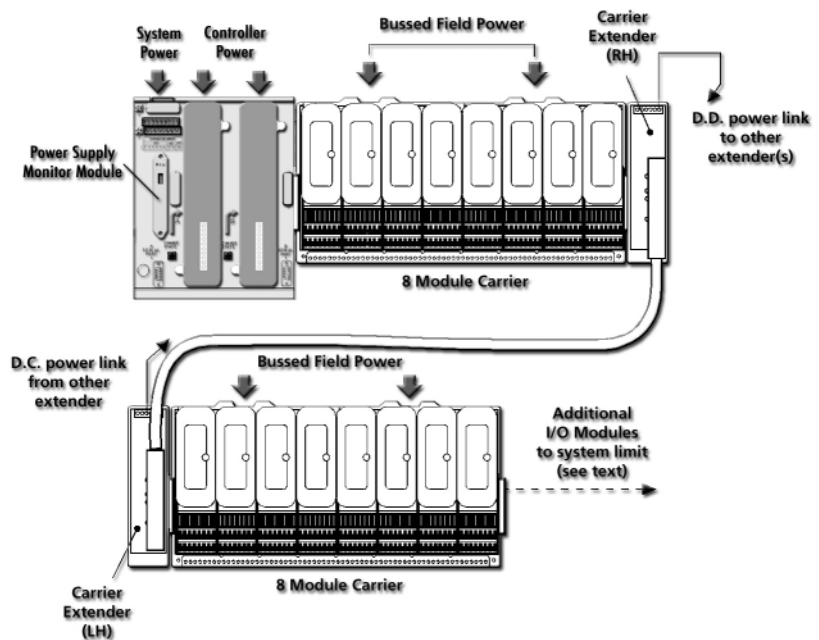

Figure 2—ELS Node Layout and Powering

ELS SAFETY CONTROLLER (ELS4851-LC-DT)



The ELS4851-LC-DT ELS Safety Controller stores and runs the ELS application program which is downloaded from the Workbench.

It manages a number of communication paths: with the IO Modules mounted on the local node via the internal Railbus;

with other entities on the Ethernet LAN (other Det-Tronics nodes, PCs running the Workbench programming tools, HMI, historian packages and asset management tools) and with remote mounted serial devices.

The ELS Safety Controller also manages the implementation of the redundancy strategy either as master or standby.

Certification

The ELS Safety Controller is certified for use in safety-related applications up to and including SIL 2. The ELS Controller achieves this Safety Integrity Level with a 1oo1D architecture (i.e. it operates in “simplex” mode, with correct operation ensured by comprehensive internal diagnostics). In such applications the ELS Safety Controller is used in conjunction with the ELS4811-IO-DC ELS Safety Digital Input/Output Module and the ELS4810-HI-TX ELS Safety Analog Input Module with HART. The ELS Safety Controller mounts on its dedicated Carrier ELS4751-CA-NS.

Type B

The ELS Controller has been designed specifically for safety-related applications and is certified on the basis of the excellence of its design (and is therefore Type B according to IEC 61508). It does not depend for its certification on “proven in use” data.

Diagnostics

If the ELS Controller’s internal diagnostics detect a fault that would prevent the ELS System from carrying out its safety function, then it will initiate a controlled shutdown. A controlled shutdown has two objectives - firstly, to ensure that the ELS System enters its failsafe mode; and secondly, to record sufficient data to allow the reason for the shutdown to be determined.

If a ELS Controller enters a controlled shutdown, then all communication with IO Modules is stopped and - when the programmed time delay for each IO module has elapsed - they will enter their safe states.

System Size

The SafeyNet Controller can interface with up to 64 locally mounted, 8-channel IO Modules - giving a total capacity of over 500 channels per node. The Ethernet LAN is capable of supporting over 200 nodes, giving a maximum theoretical capacity of over 100,000 channels.

Live Maintenance

Once the Ethernet LANs are isolated, ELS Controllers can be removed and replaced - with the local power supplies still connected - even in Division 1, Class 2 or Zone 2 hazardous areas.

Redundant Controllers

ELS Controllers can be used in a master - standby redundant configuration to improve availability of the safety function, but this is not required for safety. Introducing a redundant ELS Controller is achieved by simply inserting the new Controller in to the free slot.

The ELS system will automatically upload the required ELS application to the new Controller and initiate the redundancy algorithms. Switching between redundant Controllers on detection of a fault is automatic and bumpless.

The standby Controller continually performs the same processing, on the same data and at the same time as the Master and the results are routinely cross-checked. This ensures that the Standby is always ready to take over control from the Master. The redundancy strategy employed is known as “rendezvous redundancy”.

The “Change State” button on the Controller Carrier is depressed to switch a master to being the standby in a redundant pair, to switch a standby offline and to instruct an offline standby Controller to synchronise itself with the Controller and to enter standby. If a “where are you?” command has been issued to a particular Controller, it can be cleared from this mode (and so that it no longer flashes its LED’s) by pressing the relevant Change State button.

Serial Communications

Each ELS Controller can communicate via 2 serial ports - for which the D-type connectors are mounted one on the Controller itself, one on the Controller Carrier. The serial ports are intended for use with remote Modbus devices - for which the Controller can act as either master or slave.

HART Pass-Through

ELS Controllers can be configured to allow transparent access to the process variables and status information provided by HART field instruments. HART data cannot be used within the ELS application (as - for example - it does not employ sufficiently rigorous data error detection algorithms), but communication with such devices can be achieved by using a “passthrough” command which does not involve, nor interfere with, the ELS application.

Features

- Certified for use in SIL 2 applications, according to IEC 61508.
- Comprehensive internal diagnostics provide basis for safety architecture 1oo1D.
- Optional redundancy with bumpless transfer for increased availability.
- Dual redundant high speed fault tolerant Ethernet LAN.
- Dual redundant connections to serial devices.
- On-line configuration and re-configuration.
- Communicates with up to 64 I/O modules.
- Communicates on peer-to-peer basis with other ELS Safety and standard Controllers.
- Can write to standard output modules without compromising safety function.
- Live maintainable and hot-swappable - even in Class 1, Div 2 or Zone 2 hazardous areas.
- HART pass-through of process and status variables.
- Event logging up to 8000 events.
- 12Vdc Controller power required from ELS4913-PS-AC

CONTROLLER SPECIFICATION

See also System Specification

LAN INTERFACE

Transmission medium 100BaseTX or 10BaseT Ethernet
Transmission protocol Modbus™ over high-speed Ethernet
Transmission rates 10 - 100 Mbits/s
LAN connector type (x2) RJ 45 (8-pin)
LAN isolation (dielectric withstand) 1500 V
Action on software malfunction Halt CPU / Reset CPU

SERIAL INTERFACES (COM 1 & COM 2)

Transmission rates 1.2 – 115.2 kbits/s (async.)
Transmission standard RS485 half-duplex
COM 1 connector (on carrier) 9-pin D-type connector (F)
COM 2 connector (on controller) 9-pin D-type connector (M)

POWER SUPPLIES

Controller Power Voltage 10.9 – 12.6V dc
Controller Power Current 0.4A (typical), 0.5A (max.)
System Power Current 15mA (max.)

FUNCTIONAL SAFETY SPECIFICATION

Failure rate (λ DU)
. 87.9 dangerous undetected failures per10⁹ hours
Recommended proof test interval 3 years

MECHANICAL

Module dimensions 69 (w) x 232 (l) x 138 (h) mm
Weight (approx.) 1.35kg

HAZARDOUS AREA SPECIFICATION

Location of equipment Zone 2, IIC T4 hazardous area
. . . or Class 1, Div 2, Groups A, B, C, D T4 hazardous location

APPLICABLE STANDARDS

- Factory Mutual Research Co., Class No. 3611 for Class I, Division 2, Groups A, B, C, D hazardous locations
- CSA Std C22.2 No.213 for Class I, Division 2, Groups A, B, C, D hazardous locations
- ATEX Category 3 (for Zone 2 installation) to EN50021:1999 protection type n.

SIL 2 Certified Controller

LEDs

The ELS Safety Controller has a number of LED's that indicate the status and mode of operation of the Controller. The table below explains what they refer to and describes their operation:

NOTE

The information here given here is simplified. Additional combinations of LED states are used to provide further indication of the status of the ELS Safety Controllers. Full details are found in the relevant instruction manuals.

LED name	Colour	On	Off	Flashing
Power	Green	12V power supply to the Controller is ON.	12V power supply to the Controller is OFF.	
Master	Yellow	The Controller is the Master in a redundant pair or is in simplex mode.	The Controller is the Standby in a redundant pair.	
Healthy	Yellow	(Master) Running the application program. (Standby) Capable of running the application program.	IO data is not current - cannot take control.	(Master) Reading IO data on start-up. (Standby) Copying configuration and control parameters from the Master.
Fault	Red	If FAILSAFE LED is also ON - has performed controlled shutdown. If HEALTH LED is also Flashing - has requested a "refresh" of parameters.	For all other Controller states.	The Controller is initialising after a power cycle.
Failsafe	Red	If HEALTH LED is also ON - is in Failsafe. If HEALTH LED is OFF - is offline.	The Controller is running the application program.	No IO Module scanning is taking place and the application program is not running.
LAN A	Yellow	LED is ON when a packet of data is being transmitted.		
LAN B	Yellow	LED is ON when a packet of data is being transmitted.		
COM 1	Yellow	LED is latched ON for 2 seconds after a valid packet of data is received.		
COM 2	Yellow	LED is latched ON for 2 seconds after a valid packet of data is received.		
Safe Mode	Yellow	In SAFE mode.	In CONFIGURATION mode.	—
I/O COM	Yellow	The internal communication link (Railbus) between Controller and IO Modules is working correctly.	The internal communication link (Railbus) between Controller and IO Modules is not in use.	The internal communication link (Railbus) between Controller and IO Modules is in fault.

ELS SAFETY LOGIC WORKBENCH (ELS4841-LC-DT)

The ELS Workbench is the engineering and documentation tool for the Eagle Logic Solver (ELS) Fire & Gas Systems.

The Workbench is used to perform the following tasks:

- Configure IO Channel and Module parameters
- Configure Controller and network parameters
- Input and manage the IO tag database
- Engineer and document the control or safety application
- Generate wizards to simplify HMI design
- Simulate and test control and safety applications
- Generate reports to assist in Factory and Site Acceptance Testing

ELS Workbench

The ELS Safety Workbench has all the features of the standard Workbench, but additionally includes the special tools required for safety applications.

Safety Programming Languages

The Workbench provides three IEC61131 programming languages which can be used to write safety-related application programs:

- Ladder logic (LD)
- Function Block Diagram (FBD)
- Structured Text (ST)

Configuration Mode and Safety Responsibility

Changes to safety-related parameters are carried out with the ELS Safety Controller in “Configuration Mode”. Access to this mode is restricted to personnel with “Safety Responsibility” and its use is constrained by a number of further layers of protection for downloading parameters to ELS Safety Controllers. The ELS system defines 6 password protected levels of access authority – with only the 3 highest levels being granted “Safety Responsibility”.

Trusted Hosts

In order to prevent access to ELS Controllers by non-approved instances of the Workbench, remote Modbus devices, asset management packages and HMI, only those that the ELS Safety Controller identifies as “Trusted Hosts” can download new parameters.

Each Trusted Host is recognised by its IP and MAC addresses (remote Modbus devices are recognised by the serial port to which they are connected). For each Trusted Host a number of other restrictions can be defined:

- Modbus write not allowed
- Workbench write not allowed
- HART passthrough not allowed

Key Switch Protection

When an ELS Safety Controller is added to the Workbench the user is given the option of selecting a tag to act as a “Key Switch”. This can be used by an Operator to lock the ELS System so that Configuration Mode cannot be entered without their awareness or permission.

The Key Switch can be a physical switch, driven from an HMI screen or it can be an output from the ELS application.

Controller Passwords

When an ELS Safety Controller is added to the Workbench the user is given the option to use a Controller Password. Without the password, it is subsequently impossible to enter Configuration Mode.

On-line Download

Users with safety responsibility can download new parameters to an ELS Safety Controller, from a Trusted Host, to a Controller whose Key Switch is set to permit new downloads and where the particular ELS Safety Controller’s Password is known.

New parameter download is carried out as a background task over a number of cycles to ensure that the fault reaction and response times are not compromised. Once download is complete and the new parameters have passed the checking and security tests, the new parameters will be automatically adopted. Where redundant ELS Safety Controllers are used, the stand-by Controller will also be automatically updated. (Where a stand-by Controller is available, it may be more practical to download the new parameters to the stand-by Controller and then instruct the stand-by to become the master. The new stand-by will adopt the new parameters when instructed to do so).

NOTE

on-line download should only be used where there are adequate procedures for approving the changes that have been made and testing them prior to download.

Static Analysis Tool

Any safety-related application program must be developed by suitably qualified personnel and must be subject to careful scrutiny to ensure safety, but the Workbench provides an additional safety test. The Static Analysis Tool checks for illegal constructs within the safety program before it can be downloaded to an ELS Safety Controller.

Differences Utility

Once a new ELS application is successfully compiled, it can be downloaded to an ELS Safety Controller. On download, two text reports are generated: a Download Report and a Master Tag Xref. These can be used for comparison with earlier or subsequent downloads using the Differences Utility within the Workbench.

Change Control Log

The Workbench maintains a Change Control Log that records when:

- IO Modules are added, deleted or moved
- Tags are added to, removed from, or moved within an IO Module
- IO Configuration parameters are saved
- Controller IP addresses or node numbers are entered or modified
- External node numbers are entered or modified
- Serial communications parameters are entered or modified
- A successful download is made
- A Strategy is removed
- The Controller password is changed

ELS SAFETY I/O MODULE



The ELS Safety IO Modules interface to the safety system field wiring via Field Terminals. The IO Modules and the Field Terminals mount on Carriers that provide mechanical support, but also connect the internal communication bus and power supply connections to the Modules.

The IO Modules are certified as suitable for use in SIL 2 safety-related applications.

Certification

The ELS Safety IO Modules are certified for use in safety-related applications up to and including SIL 2. The ELS System achieves this certification with a 1oo1D architecture.

The ELS Safety IO Modules have been designed specifically for safety-related applications and are certified on the basis of the excellence of their design (and are therefore Type B according to IEC 61508). The certification does not depend on “proven in use” data.

Diagnostics

The IO Modules perform comprehensive internal diagnostic tests as an essential part of ensuring that the IO can carry out the required safety function.

If the ELS Safety IO Module's internal diagnostics detect a fault that would prevent the ELS System from carrying out its safety function, then it will initiate a controlled shutdown. A controlled shutdown has two objectives – firstly, to ensure that the IO Module enters its failsafe mode; and secondly, to record sufficient data to allow the reason for the shutdown to be determined.

If an ELS Safety Module enters a controlled shutdown, then all IO channels are deactivated: input channels are not scanned; and output channels are de-energised.

Bussed Field Power

The Bussed Field Power (BFP) connectors on the rear of IO Module Carriers provide the power connections for field instruments wired to the IO Modules.

For the ELS System, BFP must be 24V dc and supplied by Det-Tronics's ELS4914-PS-AC units. These power supplies may be used in redundant pairs, if required.

Live Maintenance

ELS IO Modules can be removed and replaced in a Class 1, Division 2 or Zone 2 hazardous area - once the relevant Bussed Field Power (BFP) connection has been isolated using an appropriate hazardous area switch. Removing and replacing the Modules does not interrupt the operation of the other parts of the node.

If a Module is replaced by another Module of identically the same type, then no intervention is required for the System to begin operating normally once the Bussed Field Power is restored.

Line Fault Monitoring

In addition to the comprehensive internal diagnostics the ELS IO Modules can monitor field wiring for line faults.

Event Logging

Data from ELS Safety IO Modules can be time stamped and stored by the ELS Safety Controller before being downloaded to the Det-Tronics SOE Data Retrieval Client or a 3rd party historian package. ELS Safety IO Module data is time stamped with a resolution of better than 200ms.

Failsafe Mode

IO Modules will enter Failsafe Mode from the Running State either due to loss of communications with the Controller or because the module has received an instruction from the Controller to enter the Failsafe State. In this state:

- The Red Fault LED is lit
- The Failsafe flag is set
- All Railbus Write requests are rejected, except instructions to Reset or to exit the Failsafe State
- Inputs and HART data are read
- Outputs are de-energised
- Background diagnostics continue and if a failure is detected, the module will enter Controlled Shutdown

Controlled Shutdown

A Controlled Shutdown is carried out if a fault is detected in the Module. In this state it can be re-started and the reason for failure captured.

LEDs

A number of LED's are provided on each IO Module to provide visual indication of the status of the Module, its channels and its power supply.

Module 'Fault' LED (red)

On - Failsafe

Off - Normal operation

Flashing (equal:mark space ratio) - Cold start in process

Blinking (On for a short period, then On for a longer period – morse code 'a') - Fault state after controlled shutdown

Module 'Power' LED (green)

On - Power OK

Off - BFP Power Failure

Module 'Status' LED's (yellow)

See Individual Module Specifications.

ELS SAFETY ANALOG INPUT MODULE (ELS4810-HI-TX)



The ELS Safety Analog Input Module with HART provides the interface to 8 channels of 4-20 mA input signals.

The ELS Safety Analog Input Module is certified for use in safety-related applications up to SIL2. In such applications the module is used with the ELS4851-LC-DT ELS Controller and ELS4811-IO-DC ELS Discrete Input/Output Module.

HART Capability

The HART capabilities of the Analog Input Module allow acquisition of secondary variables – which can be used by a standard (but not ELS) Controller as part of its application program. The Module also allows Emerson’s AMS package to communicate with any HART field device transparently, using HART pass-through.

Diagnostics

The ELS Analog Input Module carries out a number of diagnostic checks to confirm the accuracy of the measurement reported and the correct operation of the module.

In addition to the primary measurement, a second diagnostic measurement is made using different internal circuitry. The two values are then compared. The primary measurement is reported as faulty if it differs from the diagnostic measurement value by more than 2%.

Further tests are carried out on internal supply and reference voltages.

If a particular channel fails a test, then that channel is made inactive. If the failed test indicates that the Module is not working correctly, it will be shutdown.

Live Maintenance

The ELS Analog Input Module can be removed and replaced in a Class 1, Division 2 or Zone 2 hazardous area, since the connections to the Carrier and the field wiring (via the Field Terminal) are all classified as non-incendive (also known as energy limited).

It is not necessary to isolate either the Bussed Field Power or field connections prior to removing or replacing the Module.

The field wiring may also be worked upon under these conditions.

LEDs

For the operation of the Power and Fault LED’s see IO Module Overview.

Module ‘Channel’ LED (yellow)

On – Channel in range (4-20mA)

Off – Channel inactive

Flashing (equal:mark space ratio) –

Any of the following, with an active channel: line fault (indicated by the input measurement being outside the 4-20mA range), loss of HART signal, Hi-Hi or Lo-Lo alarm.

Input Sampling and Filtering

Each input channel is sampled once every 25ms and is filtered by 1st order hardware and software filters. The software filter can be disabled or set to a number of different values according to the filtering requirements of each channel.

Alarms, Deadband, Dead Zone

The Analog Input Module has a number of configurable parameters for managing setting and clearing alarms and triggering the reporting of a new input value.

Hi, Hi-Hi, Lo and Lo-Lo alarms can be configured – together with a Deadband through which the input must move before the alarm is cleared. The relationship between these parameters is shown in the diagram below.

A Dead Zone can also be configured, which is the value by which an input measurement must change before it is reported as a new value.

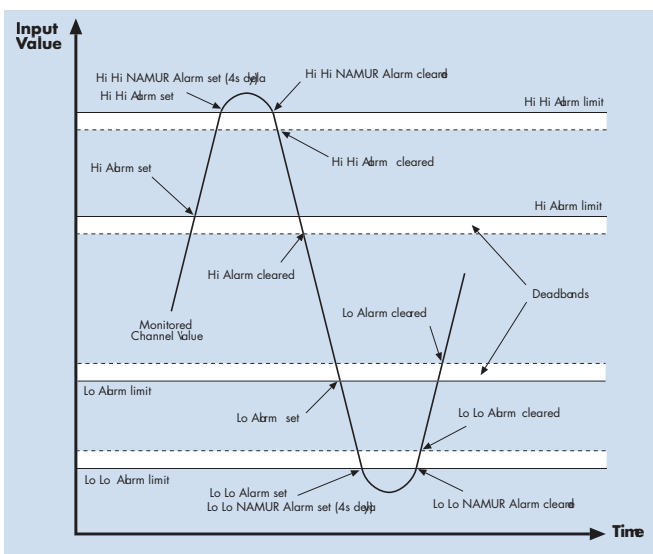

4-20 mA with HART

- 8 single ended 4-20mA input channels
- Certified for use in SIL 2 safety applications
- Non-incendive field circuits
- 2-, 3- or 4-wire transmitters
- HART pass-through, acquisition and status reporting
- 24V dc Bussed Field Power required from ELS4914-PS-AC

MODULE SPECIFICATION

See also System Specification

INPUTS

Number of channels 8, single-ended
 Nominal signal range (span) 4 to 20mA
 Full signal range 0.25 to 24mA
 Line fault detection
 Short circuit current >23.5mA
 Open circuit current < 0.5mA
 Output voltage (@ 20mA) 10.2V (min.)
 Output current 28mA (max.)
 Accuracy (over temp range) $\pm 0.1\%$ of span
 Resolution 16 bits
 Repeatability 0.05% of span
 Data format 16-bit unsigned (0-25mA = 0-65,535)
 HART data format IEEE754 floating point
 Isolation
 (any channel to Railbus) 250V ac RMS
 (between channels) none

CONFIGURABLE PARAMETERS

Alarms high, high-high, low and low-low
 Alarm deadband (hysteresis) user defined value
 Input filter time constant user defined value
 Input dead zone user defined value
 Drive on failsafe disabled /upscale /downscale
 HART variable and status reporting enable /disable

RESPONSE TIME

Signal change to availability on Railbus
 4- 20 mA mode 27ms (max.)
 HART mode 0.75s per channel

HAZARDOUS AREA SPECIFICATION

FM non-incendive field wiring parameters (each channel)
 $V_{oc} = 28.7V$; $I_{sc} = 33mA$; $C_a = 0.17\mu F$; $L_a = 11.0mH$

POWER SUPPLIES

System Power Current 100mA (typical), 150mA (max.)
 Bussed Field Power Current
 2-wire Transmitter 350mA (max.)
 4-wire Transmitter 110mA (max.)

FUNCTIONAL SAFETY SPECIFICATION

Failure rate (λ_{DU})
 16.9 dangerous undetected failures per 10^9 hours
 Recommended proof test interval 3 years

MECHANICAL

Module Key Code A1
 Module Width 42mm
 Weight 200g
 For recommended and compatible Field Terminals, see
 Field Terminal - Specification and Selection Guide.

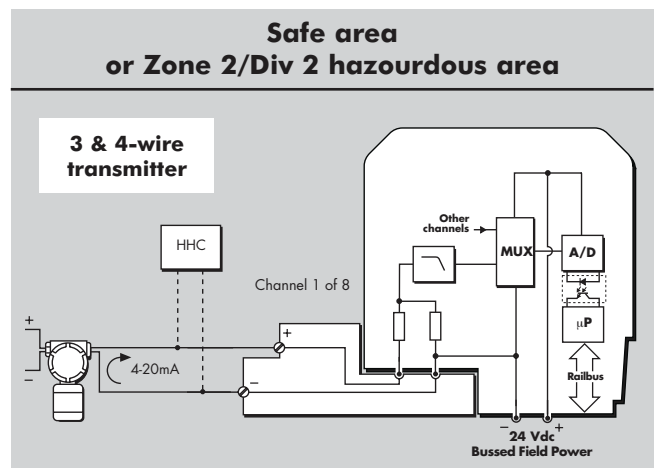
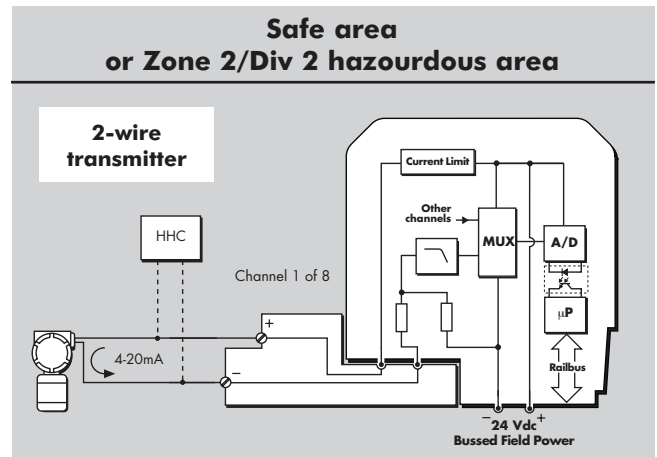

ELS SAFETY DISCRETE INPUT/OUTPUT MODULE (ELS4811-IO-DC)



The ELS Safety Discrete Input/Output Module provides the interface to 8 channels that may be configured in any combination of discrete inputs and outputs.

The ELS Safety Discrete Input/Output Module is certified for use in safety-related applications up to SIL2. In such applications the module is used with the ELS4851-LC-DT ELS Controller and ELS4810-HI-TX ELS Analog Input Module with HART.

Combined Inputs and Outputs

Each of the 8 channels of the ELS Discrete Input/Output Module may be configured, on a channel-by-channel basis, as either an input or an output.

When configured as an input, the channel is suitable for use with dry contacts – with power supplied from the Module.

When configured as an output, the channel is capable of switching up to 2.0A continuously. Output channels are used with solenoids, valves and alarms

Diagnostics

Comprehensive diagnostic tests are performed on the module and each of its channels, including tests for stuck ON and stuck OFF failures for output channels.

Live Maintenance

The ELS Discrete Input/Output Module can be removed and replaced in a Class 1, Div 2 or Zone 2 hazardous area once the Bussed Field Power (BFP) has been isolated. Once this has been done, the remaining “live” connections to the Carrier are nonincendive (also known as energy limited).

The BFP connections must be isolated as the Module and field wiring connections are non-arcing and carry incandive levels of power. If the BFP isolation device is itself in the hazardous area, then it must also have hazardous area protection.

Similarly, field wiring may only be worked upon once the BFP has been isolated.

Input Configuration

Input channels are used to interface to volt free contacts. Line fault detection can be turned OFF or can detect open circuits or both open and short.

Input Filtering

A change in the input state occurs if the states observed at the start and end of the filter time interval are the same. If they are different the previous state is maintained.

The filter time interval can be configured between 0 and 8s, in 1ms intervals.

Input Transition Counting

A counter can record the number of filtered transitions of a particular type. The counter “wraps around” from 65 535 to zero without indication.

Transitions are counted even if the channel is configured to “Latching”.

Input Latching

Inputs can be configured to “latch” a particular (filtered) input transition and maintain the output in the latched state until the latch is cleared. “Normal Polarity” will latch a transition from 0 to 1 as 1, “Inverse Polarity” will latch a transition 1 to 0 as 0. The operation is described in Figure 1.

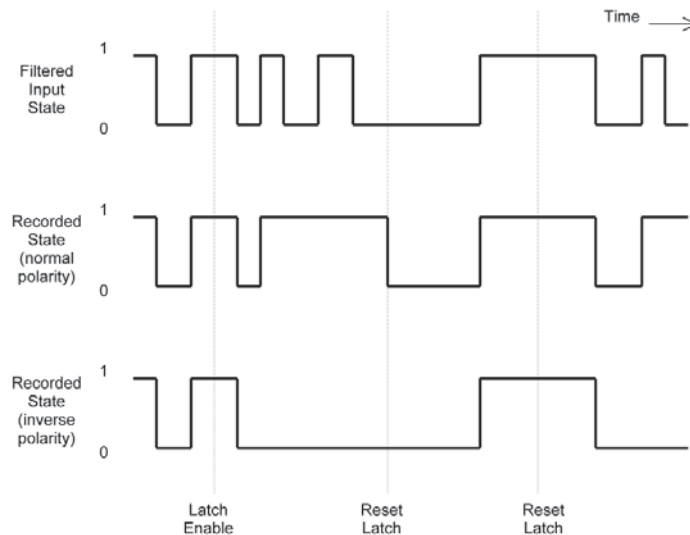

Figure 1—Recording of Input States

Normally Energised and De-energised Outputs

Individual output channels can be either normally energised or de-energised.

Each output channel comprises 2 switches that operate in series with the load – one on the supply line, the other on the return.

For normally energised outputs, if a single switch fails short circuit, the other switch can de-energise the load. If either fails open circuit, the load will be immediately deenergised by the fault.

For normally de-energised outputs, if a single switch fails short circuit, the other switch can energise the load. If either fails open circuit, the load cannot be energised.

Switches are tested by pulsing them ON or OFF for less than 5 ms – the load must not respond to this length of pulse. For normally ON outputs, this test can be disabled if required.

Pre-configured Output Patterns

A number of different, pre-defined output patterns are available, which can be used to indicate the occurrence of different events, using the same alarm hardware. The patterns are shown in Figure 2.

Pulsed Output

Output channels can be configured to give a pulsed output – of either single static, single dynamic or continuous form.

The single static pulse is ON for a predetermined time. It then remains OFF until a new pulse instruction is received.

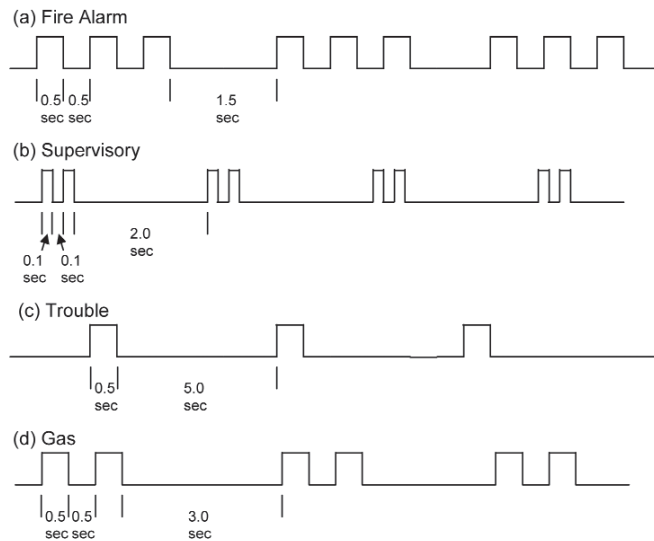

Figure 2—Pre-Configured Output Patterns

The single dynamic pulse is ON for a period that may be changed by the application, then remains OFF until a new instruction to write is received.

In continuous pulse mode a series of pulses of defined ON period are sent, with a defined OFF period between.

For all three types of Pulsed Output, the ON time of the pulse may be between 0 and 100ms in 1ms intervals.

For the continuous pulse mode, the OFF period can be set between 0 and 60s, in 1ms intervals.

Short Circuit Protection

Channels that are configured as outputs and which are short-circuited are protected by over-temperature thermal detection. If an output channel is short-circuited it will briefly conduct an over specification current, but this will be identified by the thermal detection and the relevant channel made inactive.

Line Fault Detection

Line fault detection (LFD) can be selected for inputs and normally OFF outputs. Series resistors are required for short circuit detection and end of line resistors for open circuit detection, as shown in Figure 3.

The resistor values required and default resistance value thresholds used are shown in diagram and table below:

The test current for short circuit detection maybe configured to be forward or reverse. With forward biased test currents, the threshold value for reporting a short circuit can be configured between 0 and 14Ω.

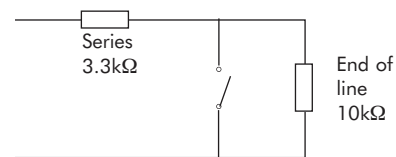

Figure 3—LFD Resistor Values

Resistance	Value
Series resistor	3.3kΩ
End of line resistor	10kΩ
Open circuit	>45kΩ
Open contact	8k - 14kΩ
Closed contact	2.5k - 5kΩ
Short circuit	>1.4kΩ

24Vdc, Non-Isolated, Module Powered Inputs and Outputs

- 8 inputs - any combination of inputs and outputs
- Certified for use in SIL 2 safety applications
- Outputs rated up to 2A continuous
- Non-arcing inputs and outputs
- Inputs for dry contact switches
- 24Vdc Bussed Field Power required from ELS4914-PS-AC

MODULE SPECIFICATION

See also System Specification

Number of channels 8
(independently configured as inputs or outputs)

INPUTS

OFF current < 0.7mA
ON current >2.24mA
Wetting current 5mA (typ.)
Minimum pulse width detected 5ms
Max input freq in pulse counting mode (no debounce) . 100Hz
Isolation (any channel to Railbus) 250V ac

OUTPUTS

Maximum Output Current per Channel 2A
Maximum Output Current per Module
Continuous 6A
Non-continuous (<10 seconds) 8A

INPUT CONFIGURABLE PARAMETERS

Filter time interval 0 to 8s (in 1ms steps)
Earth Leakage Detection Channel ON/OFF
Latch inputs enable /disable
Latch polarity latch on high / latch on low
Pulse counting enable /disable
Line fault detection none/open circuit/open & short circuit

OUTPUT CONFIGURABLE PARAMETERS

Output type pulse/discrete/pattern
Channel inactive state ON/OFF/last value
Channel initializations state ON/OFF
Pulse width 2ms to 130s
Line fault detection open line & short circuit detect

RESPONSE TIME

Input Signal change to availability on Railbus 5ms (max.)
Railbus command to output change 1ms (max.)

POWER SUPPLIES

System Power Current 50mA (typical), 75mA (max.)
Bussed Field Power Current
Channel configured as input TBA
Channel configured as output TBA

RESISTANCE MEASUREMENT ACCURACY

For open and short-circuit detection. With forward biased test current

. greater of: $\pm 4.1\% \pm 2.4\Omega$ for line resistance $\leq 220\Omega$
. greater of: $\pm 3.8\% \pm 22\Omega$ for line resistance $>220\Omega$ and $<1k\Omega$

FUNCTIONAL SAFETY SPECIFICATION

Failure rate (λ DU) – input channel

. 50.3 dangerous undetected failures per 10^9 hours

Failure rate (λ DU) – output channel

. 49.1 dangerous undetected failures per 10^9 hours

Recommended proof test interval 3 years

MECHANICAL

Module key code B6

Module width 42mm

Weight 210g

For recommended and compatible Field Terminals, see Field Terminal - Specification and Selection Guide.

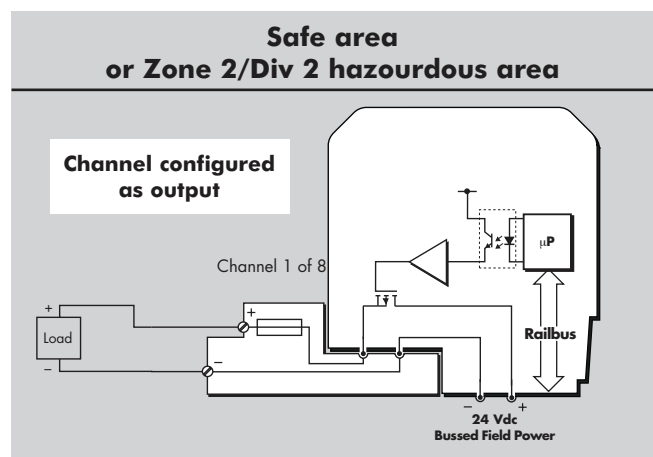
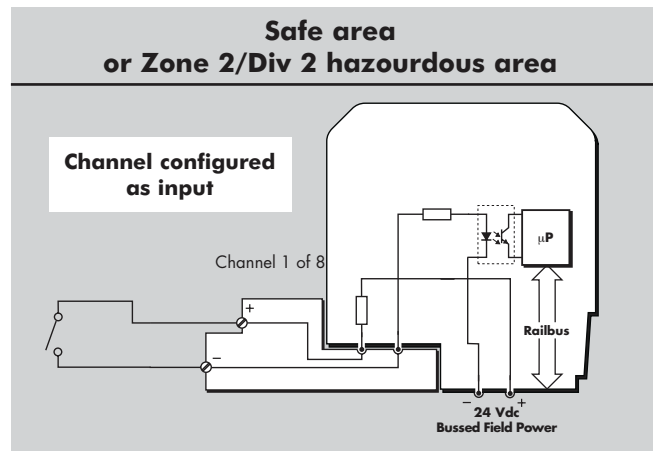

OVERVIEW OF CARRIERS

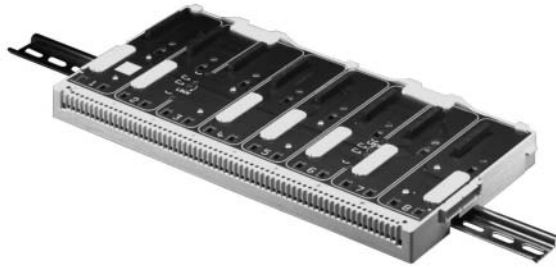

Carriers are the backplanes onto which the ELS Safety modules are mounted. A Controller Carrier is required for each node, then IO Module Carriers, Carrier Extenders and Cables can be added as required – depending on the number of IO Modules needed and their physical distribution within the cabinet or junction box.

Power and Communication

Carriers distribute “system” power to IO Modules and provide the communications route between Controllers and IO Modules. (Controller power is supplied by direct connections to the Controllers themselves).

IO Module Carriers provide connectors through which field power can be supplied (see “Bussed Field Power”). Note: field power to Intrinsically Safe IO is managed differently, see the relevant 2/1 data sheets.

Multi-pin connectors at the end of each carrier allow further Carriers to be added– and the “system” power supply and “Railbus” connections to be made.

Earthing Screens and Shields

All I/O Module Carriers have their own independent earthing/grounding strip to terminate the screens/shields of field wiring cables.

ELS Safety Controller Carrier

The ELS Safety Controller Carrier (ELS4751-CA-NS) is the dedicated Carrier for the ELS Safety System. It can support simplex or redundant ELS Safety Controllers and the Power Supply Monitor (ELS4410-NS-PS).

Serial Communications

Two D-type connectors are provided on the ELS Safety Controller Carrier for connecting to serial devices. These link to Serial Port “1” to Controller A and Controller B.

A second pair of D-type connectors is found on the Controllers themselves, to provide connections to Serial Port “2” where redundant serial communication is required.

Further details of the serial port communications are given in the data sheet for the ELS Safety Controller.

Earth Leakage Fault Detection

To comply with Fire & Gas application standards, the ELS Safety Controller Carrier can be optionally configured to facilitate earth leakage fault detection. A single channel of an 8811-IO-DC module must be allocated to Earth Leakage Detection to implement this function.

Change State Buttons

Two change state buttons are mounted on the ELS Safety Controller Carrier – one for each Controller. The button is depressed to switch a master to being the standby in a redundant pair, to switch a standby offline and to instruct an offline standby Controller to synchronise itself with the Controller and to enter standby. If a “where are you?” command has been issued to a particular Controller, it can be cleared from this mode (and so that it no longer flashes its LED’s) by pressing the relevant Change State button

Terminations for Power Fail Inputs

The ELS4913 and ELS4914 power supplies each have an output that indicates the health of the power supply. These outputs can be connected to the termination block on the ELS Safety Controller Carrier and are used by the Power Supply Monitor Module to detect failures in any of up to 7 of these external power supplies (up to six 2/2 power supplies plus one 2/1 power supply).

Module Carrier

ELS Safety Systems use the 8-module Carrier with 64-slot addressing (ELS4709-CA-08) for ELS Safety and standard modules.

Up to 8 of these may be used together to provide slots for up to 64 IO Modules.

Carrier Extenders and Cables

To allow for flexibility in cabinet layout, Carrier Extenders are provided which – together with the Extender Cables – are used to connect to Carriers mounted on different sections of the cabinet backplane or DIN rail. Carrier Extenders are used in left- and right-hand pairs.

CONTROLLER CARRIER



- accommodates two ELS Safety Controllers
- accommodates Power Supply Monitor module
- two serial port connections
- manual “ change state” buttons
- terminals for earth leakage fault detection

The ELS Safety Controller Carrier provides a mounting platform for up to two ELS Safety Controllers (ELS4751-LC-DT). It can also accommodate a Power Supply Monitor module (ELS4410-NS-PS) which can monitor the health of up to two ELS4913-PS-AC, four ELS4914-PS-AC power supplies and the 12V supply to Intrinsically Safe Modules (when these are used). For each Controller there is a serial port connector and a manually operated “Change State” button. The Carrier also provides terminals that can be used when earth leakage fault detection is required.

CARRIER SPECIFICATION

See also System Specification

CARRIER MOUNTING MODULES

ELS Safety Controller (x2) ELS4751-LC-DT
 Power Supply Monitor Module ELS4410-NS-PS

ELECTRICAL CONNECTIONS

Railbus connector male out
 Serial port connectors. 9-pin, D-type (female) (x2)
 Power Fail connections screw terminals (x7 pairs)
 Ground connections M4 screw terminal (x2)
 Earth leakage fault detection connections
 screw terminals (1 pair)
 System Power connections 6-Pin (male)
 (Note: This does not provide power to the ELS Safety
 Controllers)

MECHANICAL

Dimensions. 200 (w) x 253 (d) mm (footprint)
 Height 28 mm (top of circuit board)
 55 mm (overall)
 Weight 1.43 kg (approx.)
 Mounting methods. flat panel (4 fixings)

USER CONTROLS

Two “ change state” buttons, one for each ELS Safety Controller, are provided on the carrier. The state change depends upon the controller state before the button is pressed. See table below for effects.

State	Effect
Master	Change to standby if current standby is healthy
Standby	Change to offline state
Backup	Re-synchronise and return to standby

When earth leakage fault detection is NOT required, a link must be made - as shown - between the BFPOV and GND connection studs. The connections that must be made to implement earth leakage fault detection are described in the appropriate instruction manual.

CONTROLLER CARRIER LAYOUT

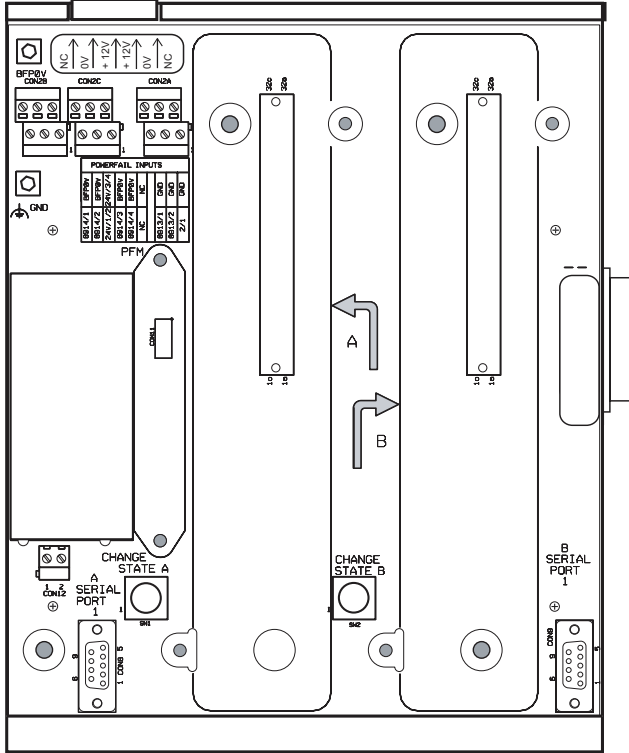

EARTH LEAKAGE FAULT DETECTION

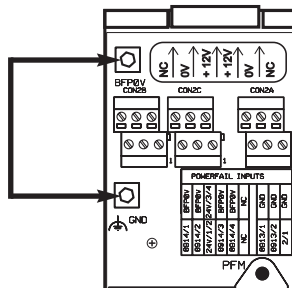

Two pairs of System Power supply connections (terminals 2/3 and terminals 4/5) are provided for wiring redundant pairs of ELS4913-PS-AC power supplies.

NOTE

The Controllers do not draw their power from these connections, they are supplied with Controller Power via connections on the Controllers themselves.

SERIAL PORT CONNECTORS (X2)



Pin #	Function
1	0V
2	NC
3	Tx/Rx (+)
4	Tx/Rx (+)
5	Tx/Rx (-)
6	Tx/Rx (-)
7	NC
8	NC
9	0V

SYSTEM POWER SUPPLY CONNECTIONS

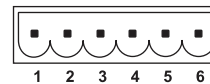

Terminal	External Power
1	No connection
2	0V
3	+12V
4	+12V
5	0V
6	No connection

PSU Power Fail Connections

These connections need only be made if the ELS4410-NS-PS Node Services Power Supply Monitor is used.

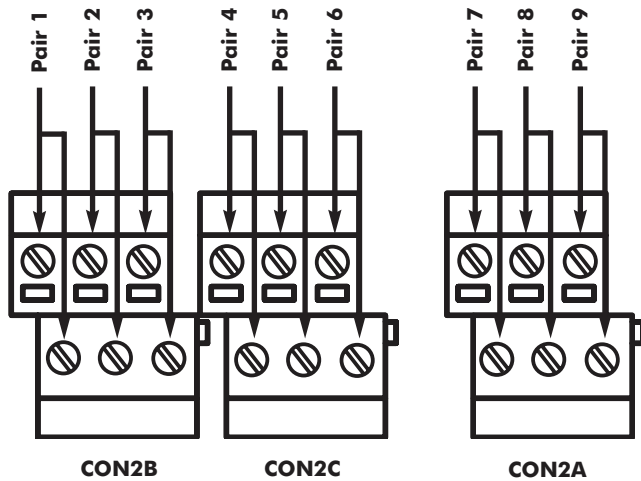

TERMINAL PAIRS 1, 2, 4 AND 5

These terminal pairs are used to monitor the AUX (or power fail) output from up to four ELS4914-PS-AC power supplies.

The upper terminal of each pair is connected directly to the AUX terminal of the ELS4914-PS-AC that is to be monitored. It is not necessary to connect the lower terminal - as this is internally connected to the BFP0V terminal on the Carrier.

If any of the ELS4914-PS-AC supplies are acting as redundant pairs, then these should be connected to terminal pairs 1 and 2 and/ or terminal pairs 4 and 5.

If a pair is unused, a shorting link must be placed between the upper and lower terminals, otherwise the Power Supply Monitor Module will continuously report a fault.

TERMINAL PAIR 3

The upper terminal of this pair should be connected to the 24V dc supply of the ELS4914-PS-AC supply monitored by terminal pair 1. The lower should be connected to the 24Vdc supply of the ELS4914-PS-AC monitored by terminal pair 4.

TERMINAL PAIR 6

This terminal pair is disconnected and should not be used.

TERMINAL PAIRS 7 AND 8

These terminal pairs may be used to monitor the AUX (or power fail) output from up to two ELS4913-PS-AC power supplies.

As for terminal pairs 1, 2, 4 and 5, a shorting link must be made between the upper and lower terminals if a pair is unused.

NOTE

Though the lower terminals are marked GND, they are connected to BFP0V in non-earth leakage fault detection applications.

Any unused pairs must be fitted with a shorting link to prevent an alarm condition being signalled to the Controller.

TERMINAL PAIR 9

If a Railbus Isolator (ELS4922-RB-IS) is not used in the node, this terminal pair must be fitted with a shorting link to prevent an alarm condition being signalled to the Controller.

MODULE CARRIER

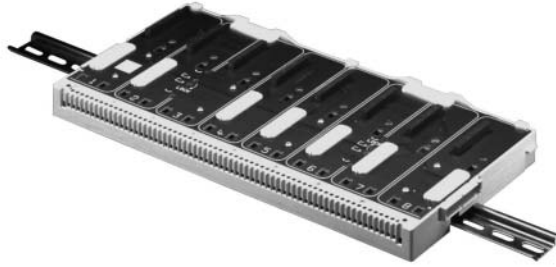

8-Module Carrier - Extended Addressing

- 64-slot address bus
- accepts up to eight ELS Safety and/or standard I/O modules
- DIN rail or panel mounting
- carries control signals and data on Railbus
- distributes System Power to modules
- distributes Bussed Field Power to modules
- isolated earthing bar for cable screens/shields

CARRIER SPECIFICATION

See also System Specification

ELECTRICAL CONNECTIONS

Railbus connectors female in, male out
 Cable screens/shield connections . . M4 screw terminals (x34)
 Bussed field power supply connectors 8-pin male (x2)
 The two 8-pin connectors provided at the top rear of the carrier connect power supplies for 'field power'. These supplies are routed through I/O modules that require power for their field circuits.

MECHANICAL

Dimensions 342 (w) x 170 (d) x 22 (h)mm
 Weight 680g
 Mounting methods Flat panel or DIN rail
 DIN-rail types
 'Top hat' 35 x 7.5mm rail or 35 x 15mm rail to EN 50022
 G-section rail to EN 50035

BUSSED FIELD POWER CONNECTOR

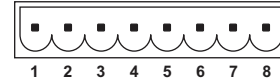

Terminal	Function
1	I/O modules 1 & 2 -ve (or Neutral)
2	
3	I/O modules 1 & 2 +ve (or Live)
4	
5	I/O modules 3 & 4 +ve (or Live)
6	
7	I/O modules 3 & 4 -ve (or Neutral)
8	

The table above gives the connection details for modules 1 to 4. The second connector provides identical connections for modules 5 to 8.

CARRIER EXTENDER

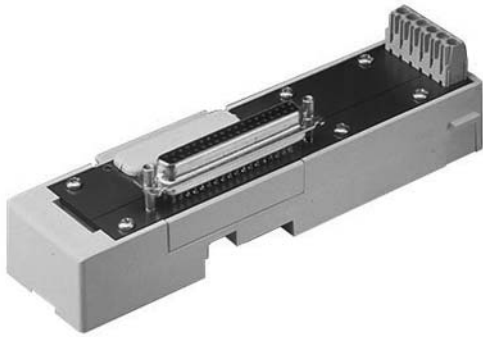

Left-Hand / Right-Hand

- ensures Railbus and power supply continuity
- pairs (left & right hand) link separate carrier runs
- sub-D connectors linked via multiway cable
- multipin connector to carrier
- maximum of 3 extender pairs per node
- 32- and 64-slot address capable

CARRIER SPECIFICATION

See also System Specification

ELECTRICAL CONNECTIONS

Railbus carrier connector

ELS4020-CE-RH female in

ELS4021-CE-LH male out

Extender cable connector Sub-D, 37-pin female

System Power cable connections* screw terminal (x6)

System Power cable conductor size 2.5mm² (max.)

* The six terminals for the System Power connections must be made in addition to connecting the Extender cable. The Terminals on the left- and right- hand extenders indicate which connections need to be made for System Power (HVCC + and HVCC -) and an internal ground connection (SGND).

MECHANICAL

Dimensions (overall) 42 (w) x 168 (d) x 37 (h)mm

Weight 135g

Mounting method integral DIN-rail fixings

DIN rail types

. 'Top hat', 35 x 7.5mm or 35 x 15mm to EN 50022

. G-section, to EN 50035

PART NUMBERS

Carrier Extender, Right-hand ELS4020-CE-RH

Carrier Extender, Left-hand ELS4021-CE-LH

CARRIER EXTENDER CABLE



0.35m, 0.85m 1.2m

- Railbus data extender cables
- three lengths - 0.35, 0.85 and 1.2 m
- Sub-D cable connectors

SPECIFICATION

See also System Specification

ELECTRICAL CONNECTIONS

Extender cable connectors Sub-D, 37-pin male (X2)

Carrier Extension Cable, 0.35m ELS4001-CC-35

Carrier Extension Cable, 0.85m ELS4002-CC-85

Carrier Extension Cable, 1.2m ELS4003-CC-12

FIELD TERMINALS



Field terminals are removable units for terminating wiring from field instruments.

Each IO Module combines with a Field Terminal to which the wiring from field instrumentation is connected.

Recommended and compatible Field Terminal types are given in the Field Terminal Specification and Selection Guide. They can be selected to optionally include loop disconnection and fusing – eliminating the need for additional terminals and wiring between the Field Terminal and the instrumentation.

By wiring directly to the Field Terminal, there is no need for additional terminals or wiring.

8-Channel Field Terminals

ELS Safety IO Modules use standard ELS 8-channel Field Terminals. Depending on the application, the Field Terminals may be for general purpose, non-arcing or nonincendive field wiring, may incorporate fused disconnects and may be for 2-, 3- or 4-wire transmitters.

Fused Disconnect

The fused disconnect Field Terminals incorporate a 2A fuse that can be partially withdrawn from the Field Terminal to act as a loop disconnect.

Tag Strip

Each Field Terminal is supplied with an integral tag strip, which is hinged to provide access to the wiring terminals and the fuse disconnects.

Field Terminal Clicks on to Carrier

The Field Terminal is easily removed from the Carrier – it is held in place by a sprung latch that can be released without the need for tools. This simplifies connection of the field wiring. The Field Terminal is secured in place by the insertion of the IO Module.

Wiring to Field Terminals

ELS Safety IO Modules all use 8-channel Field Terminals, to which wiring with a cross section of up to 2.5mm² can be connected. Each termination point is clearly numbered to simplify recognition of each terminal. The two rows of terminals are offset to allow access to the lower row when wiring is in place.

Keying

Rotary keys in the Field Terminal are adjustable to allow insertion of certain modules. Modules that would cause field wiring to be unsafe (in respect of hazardous areas) cannot be inserted.

The four types of Field Terminal can be identified from the diagram below:

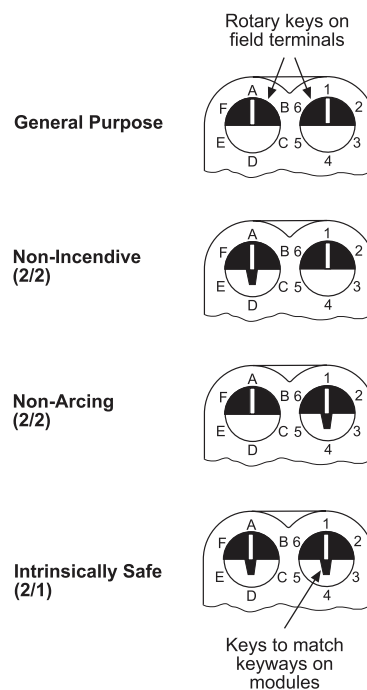

Field Terminals

- a range of Field Terminals
- standard, fused and loop-disconnect
- tag strip fitted to all Field Terminals

FIELD TERMINAL SPECIFICATION

See also System Specification

ELECTRICAL

Rated voltage 250V ac
 Maximum current per I/O channel 3A
 Fuse rating (where fitted) 2A
 Conductor size 0.14–2.5mm²

MECHANICAL

Dimensions - approx (including tagging strip)
 42 (w) x 88 (d) x 39.5 (h)mm
 Weights (typical - including tagging strip)
 Unfused type 78g
 Fused type 86g

GENERAL PURPOSE FIELD WIRING

Field terminal description	Part number
Standard	ELS4602-FT-ST
4-wire transmitter	ELS4615-FT-4W

ZONE 2/DIV2 FIELD WIRING APPLICATIONS

Field terminal description	Part number
Non-incendive fused	ELS4603-FT-FU
Non-arcing fused	ELS4611-FT-FU
4-wire transmitter	ELS4615-FT-4W

ADDITIONAL COMPONENTS

Description	No. in Pack	Part Number
2A Fuse pack	10	ELS4401-FU-2A
Loop-disconnect links pack	10	ELS4405-LK-ZE

CONNECTION DIAGRAM

The connection diagram below applies to all Field Terminals used with ELS Safety IO Modules.

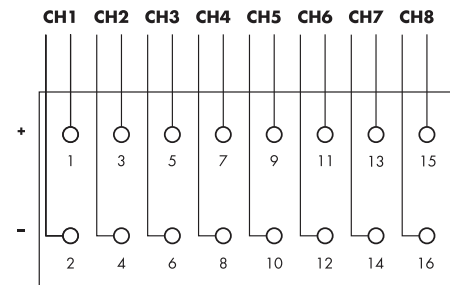

FIELD TERMINAL SELECTION

Field terminal	ELS4810-HI-TX	ELS4811-IO-DC
ELS4602-FT-ST	C	
ELS4603-FT-FU		C
ELS4611-FT-FU		R
ELS4615-FT-4W	R (3 & 4-wire TX)	

R = Recommended, C = Compatible

POWER SUPPLIES



In order to meet the relevant safety requirements, the power supplies specifically designed for use with the ELS Safety products must be used to power the ELS Safety Controller and IO Modules.

The ELS4913-PS-AC power supply must be used to supply the 12V dc for the ELS Safety Controller and System Power, and the ELS4914-PS-AC power supply must be used for the 24V dc Busbed Field Power supply to the ELS Safety IO Modules.

Redundancy

Redundancy is implemented by “pairing” each power supply with a second power supply. If the optional Nodes Services Power Supply Monitor (ELS4410-NS-PS) is used, then this can detect if there has been a failure in any one of up to six ELS4913-PS-AC/ ELS4914-PSAC power supplies and the 2/1 power supplies for nodes including Intrinsically Safe IO – and will then report that such a failure has occurred.

Wide Range of Input Voltages

The ELS4913-PS-AC and ELS4914-PS-AC power supplies accept AC input voltages in the range 85 - 264V ac.

Hazardous Area Mounting

Each power supply can be mounted in Class 1, Division 2 or Zone 2 hazardous areas.

Operating Ambient Temperature

When mounted with the optimum orientation for cooling, the power supplies will provide their full rated output in operating ambient temperatures of +70°C (provided the input range is in excess of 125V ac).

SYSTEM POWER

- 12V dc @ 5A System and Controller power
- 24V dc @ 5A for powering local instrumentation
- 85 – 264V ac input voltage
- Zone 2/Div 2 hazardous area mounting
- 12V output supports load sharing for redundancy†

POWER SUPPLY SPECIFICATION

See also System Specification

ELECTRICAL CONNECTIONS

AC Input connections screw terminals (x3)
 DC Output connections screw terminals (x8)
 Power fail signal connection screw terminal (x1)

INPUT SPECIFICATION

Input voltage 85–264V ac
 Input frequency 47–65Hz
 Power efficiency Up to 87 %
 Input protection internal (6.3A) slow-blow fuse and VDR*

OUTPUT SPECIFICATION

DC24V output voltage 24.7V dc ± 10%
 DC12V output voltage 11.95V dc ± 5%
 DC24V output current 5A (nominal - see Figure1)
 DC12V output current 5A (nominal - see Figure 1)
 Input-output isolation 2800V dc
 Hold-up time (at full rated load) 15ms (typ.)
 Thermal protection reduced output power
 Supply health indicator LED

POWER-FAIL SIGNALLING - DC12V OUTPUT ONLY

Threshold to trigger "power-fail" signal 11.33V (max.)
 10.30V (min.)

POWER-FAIL SIGNAL OUTPUT (OPEN COLLECTOR)

Power supply "OK" . . . Low impedance to –ve of DC12V output
 Power supply "failure" High impedance to –ve of DC12V output

MECHANICAL

Dimensions . . . 103 (w) x 138 (h) x 113.6 (d)mm (see Figure 4)
 Mounting methods 35 mm x 7.5 mm T-section DIN rail
 (see also Accessories overleaf)
 Weight 750g

APPROVALS

EMC compliance To EN 61000-2,3,4,5,6,11
 EN 55011/22, EN 55014
 Electrical safety To EN 60950

HAZARDOUS AREA STANDARDS

- Factory Mutual Research Class No. 3600/3611 for Class I, Division 2, Groups A, B, C, D hazardous locations
- ATEX Directive 94/9/EC Category 3 - II 3 G
- CENELEC standard EN50021:1999 EEx n A II T4

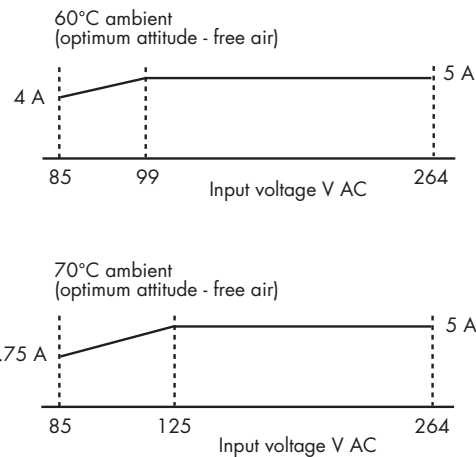

Figure 1—DC24V and DC12V Output Current De-rating

† The 24Vdc output does not support load sharing and should only be used for supplying local 24Vdc instrumentation. It should not be used to supply 24Vdc Bussed Field Power.

* voltage dependent resistor

Terminal Assignments

INPUT CONNECTOR SCREW TERMINALS

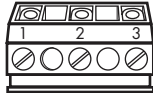
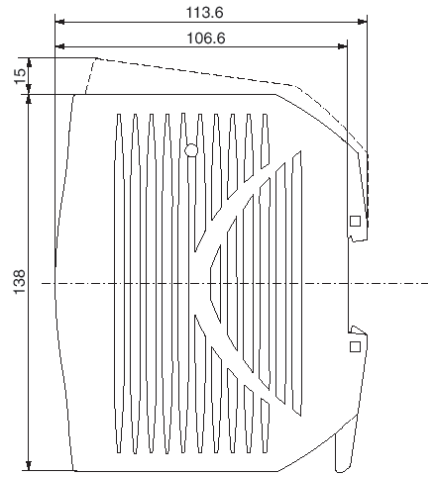

Figure 2 - AC Input Connector

Terminal	Des.	Description
1		Protective earth
2	N	Input neutral
3	L	Input live



OUTPUT CONNECTOR SCREW TERMINALS

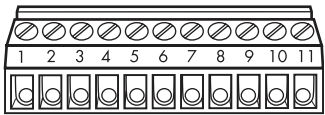

Figure 3 - DC Output Connector

Terminal	Des.	Description
1		Not connected
2	+	Output 1 + ve
3	+	Output 1 + ve
4	-	Output 1 - ve
5	-	Output 1 - ve
6	+	Output 2 + ve
7	+	Output 2 + ve
8	-	Output 2 - ve
9	-	Output 2 - ve
10	Aux.	Power fail signal
11		Not connected

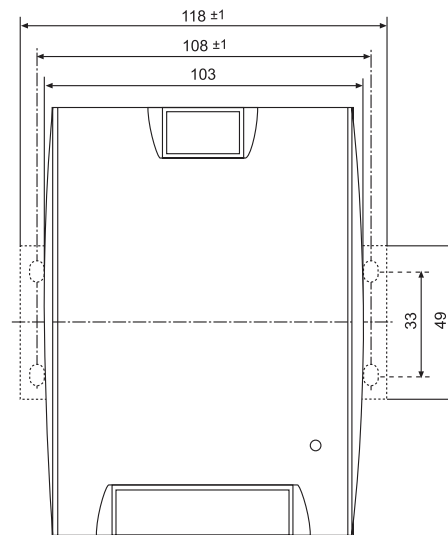

Figure 4—Outline and Fixing Dimensions

Accessories

Heavy duty DIN rail mounting kit* ELS4413-FK-DN

Surface panel mounting kit ELS4414-FK-SU

* For high vibration environments

BUSSED FIELD POWER



- 24V dc @ 10A for Bussed Field Power
- 85 – 264V ac input voltage
- Zone 2/Div 2 mounting
- supports load sharing for redundancy

POWER SUPPLY SPECIFICATION

See also System Specification

ELECTRICAL CONNECTIONS

AC Input connections screw terminals (x3)
 DC Output connections screw terminals (x8)
 Power fail signal connection screw terminal (x1)

INPUT SPECIFICATIONS

Input voltage 85–264V ac
 Input frequency 47–65Hz
 Power efficiency up to 87 %
 Input protection internal (6.3A) slow-blow fuse and VDR*

OUTPUT SPECIFICATIONS

Output 24V dc ± 10%
 Output current 10A (nominal - see Figure 1)
 Input-output isolation 2800V DC
 Hold-up time (at full rated load) 15ms (typ.)
 Thermal protection reduced output power
 Supply health indicator LED

POWER-FAIL SIGNALING

Threshold to trigger "power-fail" signal 23.3V (max.)
 22.0V (min.)
 Power-fail signal output (open collector)
 Power supply "OK" low impedance to ground
 Power supply "failure" high impedance to ground

MECHANICAL

Dimensions 103 (w) x 138 (h) x 113.6 (d)mm (see Figure 4)
 Mounting methods 35mm x 7.5mm T-section DIN rail
 (see also Accessories overleaf)
 Weight 750g

*voltage dependent resistor

ELECTRICAL

EMC compliance To EN 61000-2,3,4,5,6,11
 EN 55011/22, EN 55014
 Electrical safety To EN 60950

APPLICABLE STANDARDS

- Factory Mutual Research Co., Class No. 3611 for Class I, Division 2, Groups A, B, C, D hazardous locations
- ATEX Category 3 for Zone 2

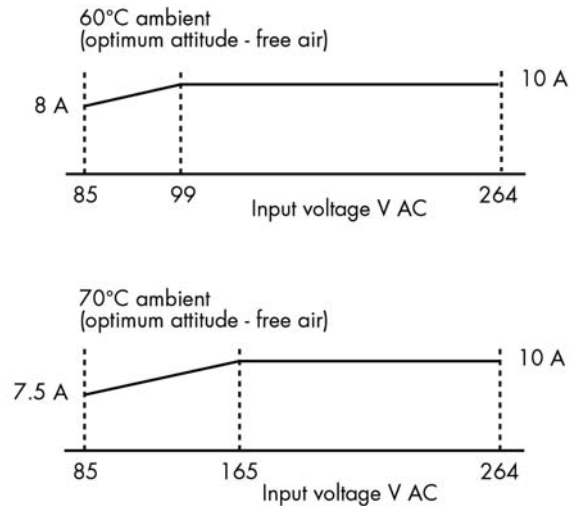

Figure 1—Output Current De-rating

Terminal Assignments

INPUT CONNECTOR SCREW TERMINALS

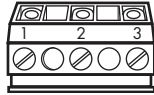
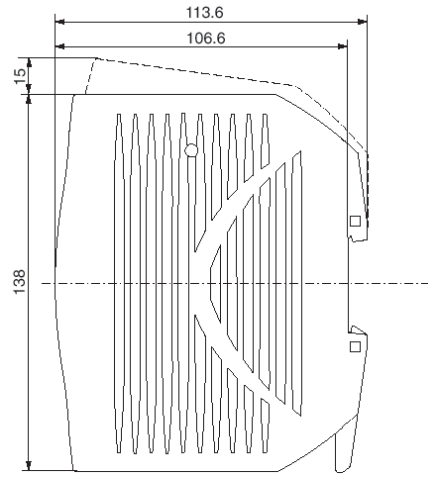

Figure 2 - AC Input Connector

Terminal	Des.	Description
1		Protective earth
2	N	Input neutral
3	L	Input live



OUTPUT CONNECTOR SCREW TERMINALS

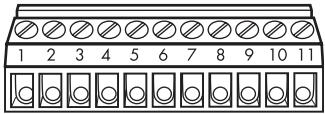

Figure 3 - DC Output Connector

Terminal	Des.	Description
1		Not connected
2	+	Output + ve
3	+	Output + ve
4	-	Output - ve
5	-	Output - ve
6	+	Output + ve
7	+	Output + ve
8	-	Output - ve
9	-	Output - ve
10	Aux.	Power fail signal
11		Not connected

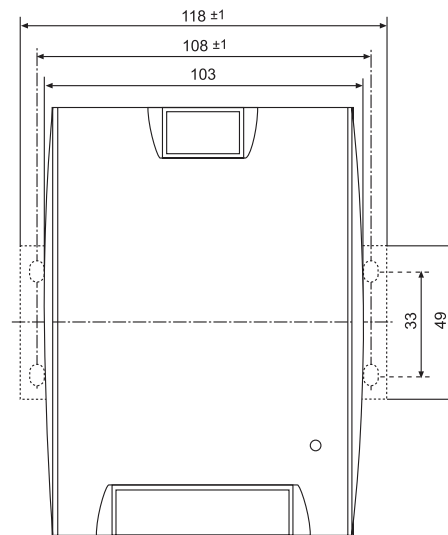

Figure 4—Outline and Fixing Dimensions

Accessories

Heavy duty DIN rail mounting kit* ELS4413-FK-DN

Surface panel mounting kit ELS4414-FK-SU

* For high vibration environments

NODE SERVICES POWER SUPPLY MONITOR



- power supply status monitoring for ELS4913-PS-AC and ELS4914-PS-AC power supplies
- indicates supply failures to ELS Safety Controller
- monitors up to two ELS4913-PS-AC, four ELS4914-PS-AC power supplies and the 2/1 supply for nodes including IS IO modules
- Zone 2/Div 2 hazardous area mounting
- mounts on ELS4571-CA-NS Carrier

The Power Supply Monitor can monitor the health of supplies powering an ELS Safety node and signal the Controller in the event of any one of them failing. The module can receive power supply status signals from up to two ELS4913-PS-AC and four ELS4914-PS-AC power supplies. It can also monitor the status of ELS4920-PS-DC supplies powering intrinsically safe I/O modules. Where power supply redundancy is employed, the module enables failed power supplies to be identified and replaced without interference to the process. The module itself may be removed and replaced in a Zone 2/Div 2 hazardous area without gas clearance.

MODULE SPECIFICATION

See also System Specification

POWER CONSUMPTION

Railbus (12V) current 5mA (typ.)
 10mA (max.)

LED INDICATOR

PWR (i.e. System power supply present)

MECHANICAL

Mounting method (captive x2) screw fixing
 Weight (approx.) 75g

DIMENSIONS

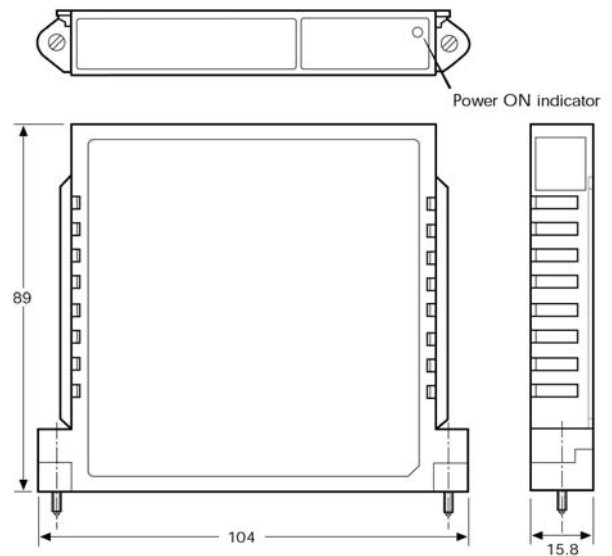

Dimensions in mm

SYSTEM SPECIFICATION

ENVIRONMENTAL

OPERATING AMBIENT TEMPERATURE

Optimum orientation* -40°C to +70°C
Non-optimum orientation -40°C to +50°C
Storage -40°C to +85°C
Relative Humidity. 5 to 95% (non-condensing)
Ingress protection. IP20 to BS EN60529: 1992
Corrosion resistance Designed to meet ten year service in Class G3 corrosive environment, as per ISA S-71.04: 1985 “Environmental Conditions for Process Measurement and Control Systems: Airborne Contaminants”.

* With field terminals vertically above or below the IO Modules.

OPERATING VIBRATION RESISTANCE

DIN rail mounted*
. 1g (sinusoidal vibration 10 – 500Hz to EN 60068-2-6)
. 1g (random vibration 20 – 500Hz to BS2011: Part 2.1)
Surface mounted.
. 5g (sinusoidal vibration 10 – 500Hz to EN 60068-2-6)
. 5g (random vibration 20 – 500Hz to BS2011: Part 2.1)

* The ELS Safety Controller Carrier ELS4751-CA-NS can only be surface mounted.

OPERATING, STORAGE AND TRANSPORTATION VIBRATION RESISTANCE

30g peak acceleration, with 11ms pulse width (EN 60068-2-27)

STORAGE AND TRANSPORTATION SHOCK RESISTANCE

. 1m drop onto flat concrete (EN 60068-2-32)

MECHANICAL

DIN-rail types. 'Top hat', 35 x 7.5mm to EN 50022
. 'Top hat', 35 x 15 mm to EN 50022
. G-section, to EN 50035

ISOLATION

Between ELS Safety channels none
Channel (any) to railbus 250V ac rms

NODE SIZE LIMITATIONS

Maximum physical length of railbus* 6.8m
Maximum number of extender cables 3
Maximum number of IO Modules 64
Maximum number of ELS Safety nodes 249

* overall including backplanes and extender cables

HAZARDOUS AREA APPROVAL

ELS SAFETY NODE LOCATION

. Safe area or
. Zone 2, IIC, T4 hazardous area
. Class 1, Div 2, Groups A-D T4 hazardous location

FIELD EQUIPMENT AND WIRING LOCATION

. Safe area or
. Zone 2, IIC hazardous area
. Class 1, Div 2, Groups A-D hazardous location
(Temperature classification will be determined by the field apparatus)

APPLICABLE HAZARDOUS AREA STANDARDS:

- Factory Mutual Research Co., 3611: 2004. “Non-incendive Electrical Equipment for use in Class I and II, Division 2, and Class III Divisions 1 and 2, Hazardous (Classified) Locations”.
- CSA C22.2 No 213-M1987, Reaffirmed 2004. “Nonincendive Electrical Equipment for Use in Class I, Division 2 Hazardous Locations”.
- EN 60079-0:2004 “Electrical apparatus for potentially explosive atmospheres, general requirements”.
- EN 60079-15: 2003 “Electrical apparatus for potentially explosive atmospheres, type of protection ‘n’”.

ELECTRICAL STANDARDS AND APPROVALS

APPLICABLE EMC STANDARDS

- EN 50270:1999. “Electromagnetic Compatibility - Electrical apparatus for the detection and measurement of combustible gases, toxic gases or oxygen”
- EN 50130-4:1996. “Electromagnetic compatibility- Product family standard: Immunity requirements for components of fire, intruder and social alarm systems”
- EN 61326: 1997. “Electrical Equipment for Measurement, Control and Laboratory Use – EMC requirements”.

APPLICABLE ELECTRICAL SAFETY STANDARDS

- IEC 61131-2: 2003. “Programmable controllers, Equipment requirements and tests”.
- EN 61010-1: 2001 “Safety requirements for electrical equipment for measurement, control and laboratory use – Part 1: General Requirements”.

SAFETY APPROVALS

APPLICABLE FUNCTIONAL SAFETY STANDARDS

- IEC 61508:2002. “Functional Safety of Electrical/Electronic/Programmable Electronic Safety-related Systems”
- IEC 61511:2003. “Functional Safety - Safety Instrumented Systems for the Process Sector”.

FUNCTIONAL SAFETY SPECIFICATIONS

Certified for use up to	SIL2	Configuration	1oo1D
Architecture Type	B	Hardware Fault Tolerance	0
Failure Rate Data			
Part	Model	λ_{DU} (dangerous undetected failure rate per 10^9 hours)	
ELS Safety Controller	ELS4851-LC-DT	87.9	
AI ELS Safety Module	ELS4810-HI-TX	16.9	
DI/DO ELS Safety Module - channel configured as input	ELS4811-IO-DC	50.3	
DI/DO ELS Safety Module - channel configured as output	ELS4811-IO-DC	49.1	
Safe Failure Fraction		>90%	

CABLE PARAMETERS FOR NON-INCENDIVE FIELD WIRING

Module (each channel)	FM		
	Gas Group	Ca (μ F)	La (mH)
ELS4101-HI-TX	A+B	0.17	11
	C	0.51	33
	D	1.36	88